











ASSEMBLY INSTRUCTIONS (INSTRUCTIONS D'ASSEMBLAGE)

HARDWARE LIST (LISTE DES OUTILS):

NO.	Sketch	Description	Qty
NO.	Schéma	Description	Qté
A		Bolt (1/4" * 1/2") Boulon	4 PCS 4 PCES
B		Bolt (1/4" * 5/8") Boulon	4 PCS 4 PCES
C		Bolt (1/4" * 7/8") Boulon	2 PCS 2 PCES
D		Washer (1/4" * Ø19) Rondelle plate	4 PCS 4 PCES
E		Washer (1/4" * Ø16) Rondelle plate	4 PCS 4 PCES
F		Spring Washer (1/4") Rondelle frein	4 PCS 4 PCES
G		Allen wrench (4mm) Clé hexagonale	1 PC 1 PCE

PARTS LIST (LISTE DES PIÉCES):

NO.	Sketch	Description	Qty
NO.	Schéma	Description	Qté
1		Glass Top Vitre de table	1 PC 1 PCE
2		Inner Frame Armature interne	1 PC 1 PCE
3		Outer Frame Armature extérieure	1 PC 1 PCE
4		Base Base	1 PC 1 PCE

Step 1 / Étape 1

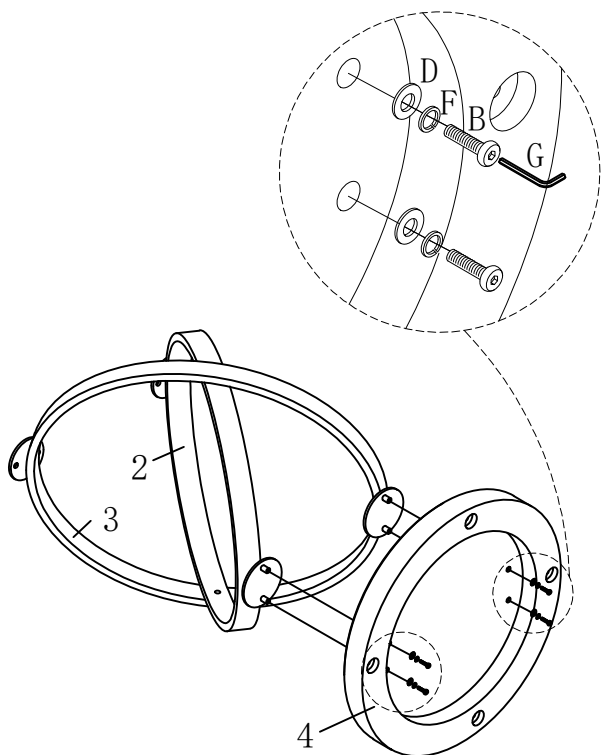

Step 2 / Étape 2

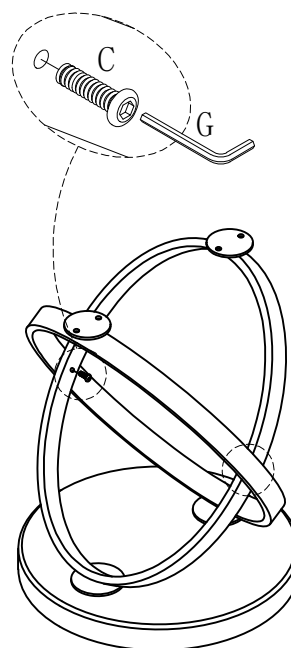

Note: At this stage, do not fully tighten the bolts .

À noter qu'il ne faut pas serrer complètement les boulons à ce stade.

ASSEMBLY INSTRUCTIONS (INSTRUCTIONS D'ASSEMBLAGE)

Step 3 / Étape 3

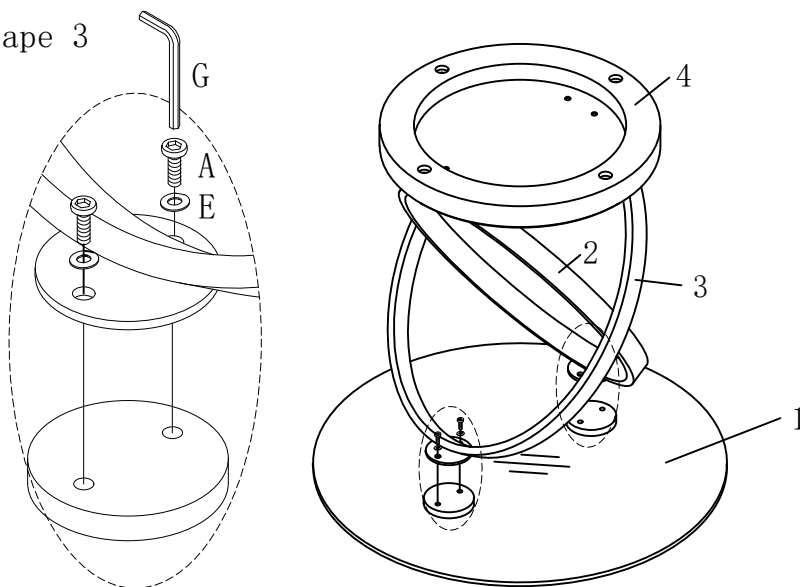

Note: Do not full tighten all bolts until complete assembly.
Tel qu' illustré. Attendre avant de serrer complètement les boulons.

Step 4 / Étape 4

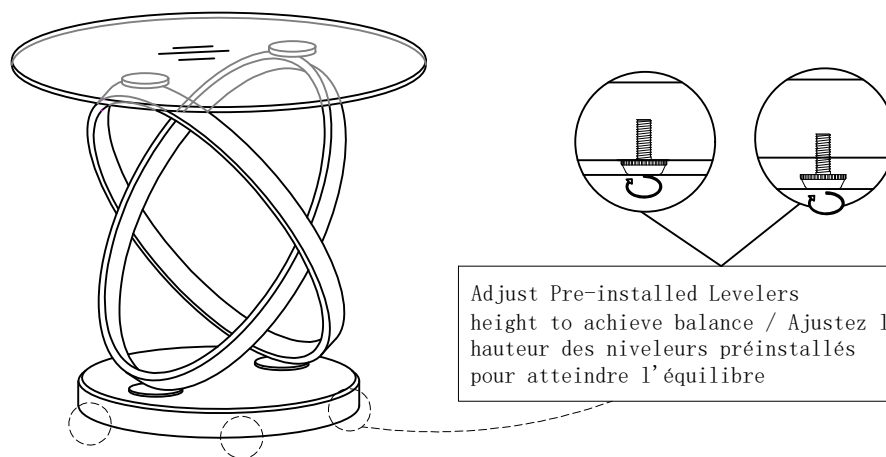

Step 5 / Étape 5

